

NESS

GEARLESS TEMPERATURE GAUGE SERIES

Instruction Manual

【Gearless Temperature Gauge】

【Gearless Temperature Switch】

【Gearless Explosion-Proof Temperature Switch】

NESSTECH INC.

~ I N D E X ~

- 1. Safety precautions P1~2
- 2. Disclaimer and
terms and scope of warranty P3
- 3. Transportation, storage,
and unpacking precautions P3
- 4. Mechanism and
general specification P4~6
- 5. Installation P7~9
- 6. Operation P10~15
- 7. Maintenance P16~18
- 8. Trouble-shooting P19

1. Safety precautions



(1) Preface

- The gauges are precise instrumentation. Please handle with care.
- Proper installation, operation, and maintenance is essential in order to use the product safely. Please read and fully understand this manual before installation, operation, and maintenance.
- First confirm that the gauge on hand is exactly as per your required specifications.
- Mishandling will lead to breakage and may cause injuries or accidents.
- This manual may not cover all the necessary information. Please consult your nearest Nesstech representative for assistance in case you need any information other than what is listed in this manual.
- We reserve the rights to revise the content of this manual without any prior notice.
- This manual is intended to be kept at the customer's (final user) location.

(2) Standard of precautions

Precautions are defined in three levels, "Danger", "Warning", and "Caution" to describe the extent and urgency of dangers and damages. They are all important aspects to keep in mind for your safety.

(3) Definition of precautions

 Danger	Precaution to avoid urgent situations when mishandling of the product <u>may lead to a very high possibility of death or serious injury.</u>
 Warning	Precaution to avoid situations when mishandling of the product <u>may lead to a possibility of death or serious injury.</u>
 Caution	Precaution to avoid situations when mishandling of the product may lead to slight injury or property damage.

※There are possibilities of serious accidents even when the precaution level is "caution".

Each criteria describes important contents and they all must strictly be followed.

Danger

- Do not use the product against corrosive medium. Thermo-bulb or thermowell could get damaged or burst, and process medium may eject leading to injuries or damages.
- Please make sure to select a material that is most suitable for the process medium.
Process medium may damage the thermowell and process medium may eject leading to injuries or damages.
- Always use a thermowell where there is flow.
- Do not open the case when installed in an explosive atmosphere. It may lead to explosion.

Warning

- Make sure the connection is completely sealed without any leakage. Failure to do so may lead to indication error and malfunction.
- Do not use the product except under the designated standard and temperature/pressure to prevent breakage or leakage which may lead to serious accidents
- Do not apply excessive load, shock, or vibration. It may lead to injuries or damages.
- Do not touch the product when measuring high temperature. It may lead to injuries.
- Strictly follow the safety guide for electric equipment for installation in explosive atmosphere.
- Do not use the product as a scaffold. It may break the product and lead to damages or accidents.
- Do not modify or disassemble the product. It could break the product or cause injuries.
- Do not proceed with the wiring work with wet hands or when energized.

Caution

- Do not hold and twist the gauge by hand during installation. Please always use a wrench on the socket.
- Do not use the product without all the parts (cover, glass, gasket) in place to prevent breakage.
- Do not snap or bend the pointer during zero adjustment to prevent breakage. Please follow the procedure on page 16.
- Do not touch the indicating pointer (except during zero adjustment) or the setting pointer directly. It may damage the product.
- Do not hit the product with any kind of tools. Damages could cause leakage of the medium or indication error which may lead to accidents.
- Install the product vertically. If the dial is not vertical, the internal mechanism could get damaged and accuracy may be affected. Please contact us in case of mounting other than in vertical position
- Product may not operate correctly or be damaged if wiring is not properly connected.

2. Disclaimer and terms and scope of warranty

(1) Disclaimer

Nesstech accepts no liability for damage, injury or any legal responsibility incurred directly or indirectly from the use of this product. The user shall observe safe and lawful practices including, but not limited to, those set forth in this manual.

(2) Warranty term

2 years from the date of delivery

(3) Warranty scope

Nesstech will be responsible and will repair or supply replacements for damage or breakage during the above period. However, the following cases will not be applicable.

- (a) Problems caused by inappropriate handling and/or safekeeping by the user.
- (b) If the reason of damage or breakage is not caused by the product itself.
- (c) Problems caused by modification, disassembling, or repairing by other than Nesstech.
- (d) Problems caused by using the product improperly, disregarding the contents of this manual.
- (e) Problems caused by natural calamities, or any other damages by the event of force majeure.

Please be aware that it may be difficult to find out the actual cause of damage even after factory investigation.

Terms and scope of Warranty applies only for the product itself, and Nesstech will not be responsible for any other damage or loss.

3. Transportation, storage, and unpacking precautions

(1) Transportation

Please keep the product vibration and shock free during transportation to avoid product failure.

(2) Safekeeping

Keep the product where the ambient temperature is stable within -10~50°C.

Keep the product in dry area where humidity is low with less vibration and dust.

In case of long-term storage, follow the "This side up" mark on the box and carefully pile each box

horizontally so the boxes will maintain its' original shape.

(3) Unpacking

Unpack carefully. First confirm that the gauge on hand is exactly as per your required specifications, and check for any damages that may have occurred during transportation.

Please be careful not to drop the product by accident when unpacking. In case you notice anything unusual, please contact Nesstech or the agent you purchased the product from.

4. Mechanism and general specification

(1) Internal structure

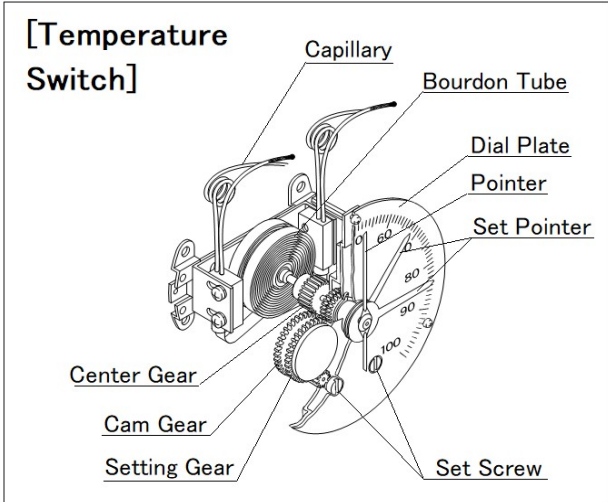
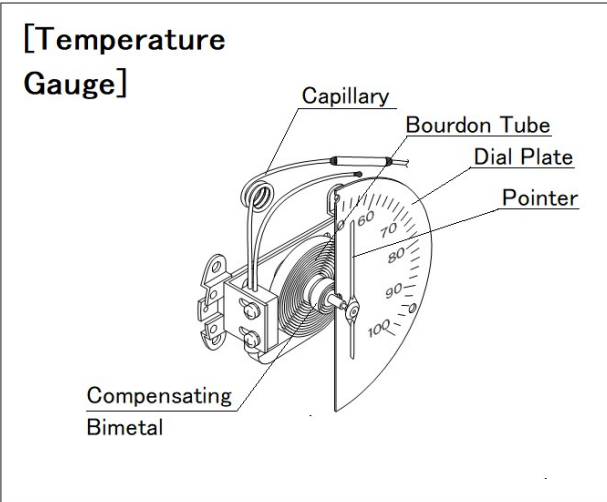

(2) External view

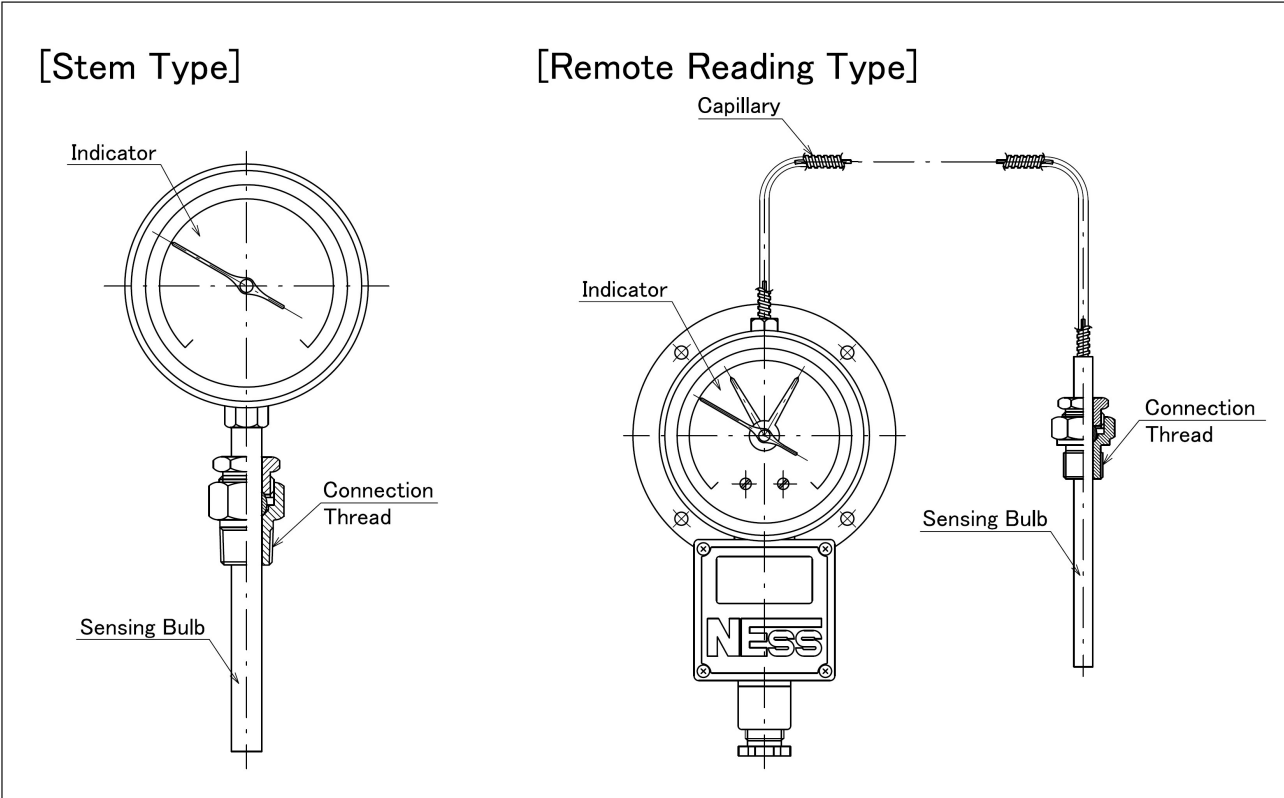

(3) Mechanism of temperature gauge

When the sensing-bulb sense a temperature change, liquid or gas filled inside the tank located at the tip will expand/contract. The capillary will transfer the volumetric change of liquid or gas to the bourdon tube, which will convert the volumetric change to a rotational movement and indicate the measuring temperature.

There are 2 types of ambient temperature compensation. Case compensation having a bimetal coil inside the case, and Full compensation having an additional bourdon and capillary built-in the internal mechanism.

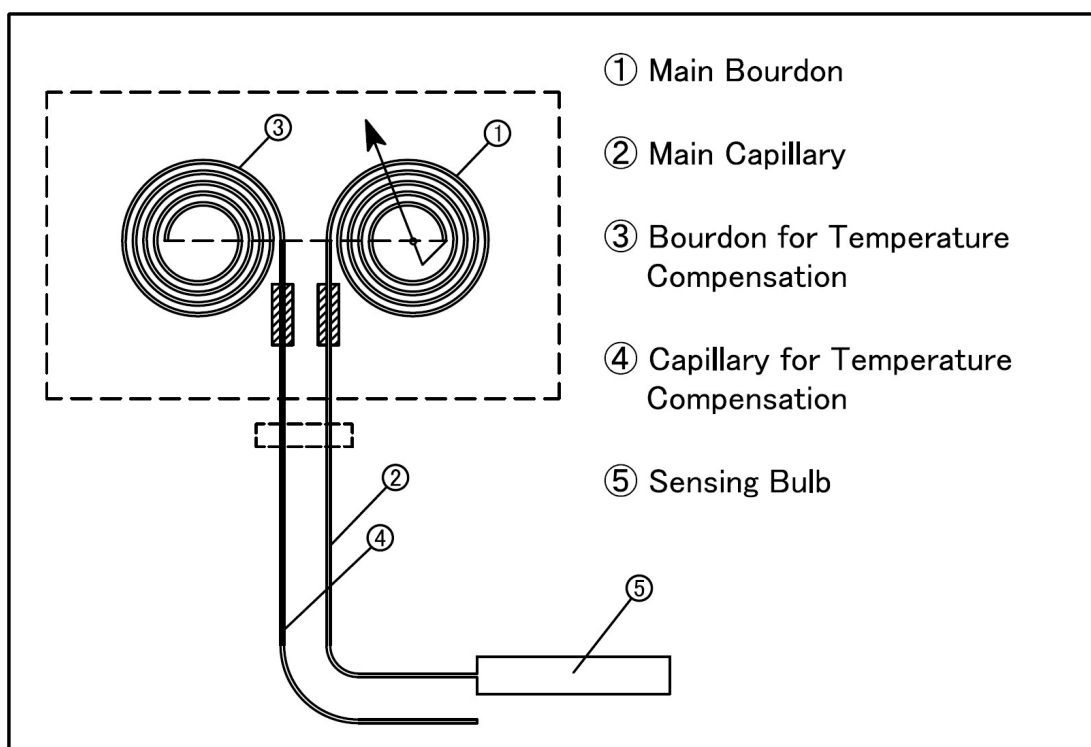
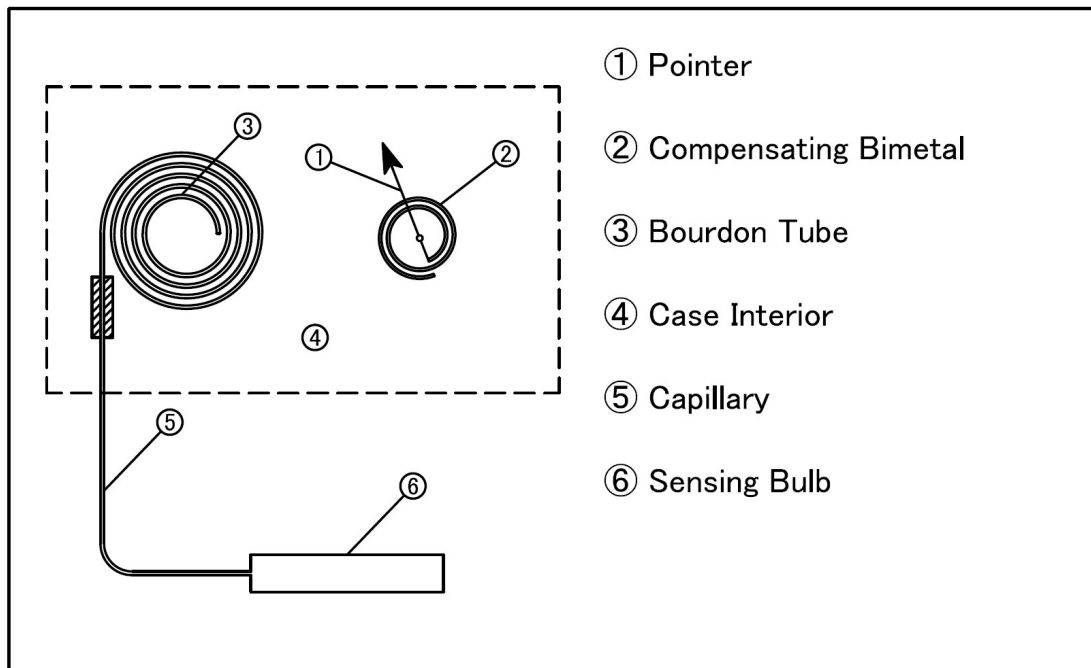

(4) General specification

Temperature Gauge

Dial size	φ75	φ100	φ150		
Case material	Aluminum with black epoxy painting, or Stainless Steel				
Scale plate	White back ground with black figure (red figure on negative side)				
Temperature range	-200(Min.) ~ 600°C(Max.)				
	Liquid expansion	-100(Min.) ~ 350°C(Max.)			
	Gas expansion	-200~50°C	0~400°C	0~500°C	0~600°C
Temperature compensation	Case compensation (single capillary / model-S)				
	Full compensation (double capillary / model-D)				
Sensing-bulb	SUS316				
Sensing-bulb O.D.	φ8	φ10	φ12	φ14	
Capillary	Liquid expansion	50m (Max.)		Full compensation for longer than 11m	
	Gas expansion	30m (Max.)		Case compensation only	
Accuracy	±2.0%F.S.				
Ambient Temp.	-10~50°C				

Temperature Switch

Dial size	Weather proof	φ75, φ100, φ150			
	Explosion proof	φ75, φ100			
Case material	Weather proof	Aluminum with black epoxy painting			
	Explosion proof	Aluminum with black painting (satin finish)			
Scale plate	White back ground with black figure (red figure on negative side)				
Temperature range	-200(Min.) ~ 600°C(Max.)				
	Liquid expansion	-100(Min.) ~ 350°C(Max.)			
	Gas expansion	-200~50°C	0~400°C	0~500°C	0~600°C
Temperature compensation	Case compensation (single capillary / model-S)				
	Full compensation (double capillary / model-D)				
Sensing-bulb	SUS316				
Sensing-bulb O.D.	φ8	φ10	φ12	φ14	
Capillary	Liquid expansion	50m(Max.)		Full compensation for longer than 11m	
	Gas expansion	30m(Max.)		Case compensation only	
No. of set point	1 set point / 2 set points				
Electrical conduit	Marine cable gland(15a/20a), DIN connector, Ex-proof cable gland, etc.				
Accuracy	±2.0%F.S.				
Set point accuracy	Accuracy: ±1 scale division		Deadband: Within 4 scale division		
Ambient Temp.	-10~50°C				

*Please refer to the catalogue for information not listed in the chart above.

5. Installation *Please go through the “Safety precautions” before you start any installation work

(1) Indicator

- Install the indicator correctly as per the drawing and catalogue.
- Install in an area where there is less effect of vibration.
- Anti-vibration performance is not only determined by the value of acceleration (G) but also by multiple conditions such as vibration cycle and amplitude. Please consult your nearest distributor or sales office in case vibration is becoming a problem.
- Install in an area where there is less ambient temperature fluctuation.
- Please drill three (or four) M4 holes with P.C.D. $\phi 100$ for installation of $\phi 75$ capillary type gauge.
- Please drill three (or four) M6 holes with P.C.D. $\phi 125$ for installation of $\phi 100$ capillary type gauge. For model TUHA, please refer to the drawing below.
- Please drill three (or four) M6 holes with P.C.D. $\phi 190$ for installation of $\phi 150$ capillary type gauge.
- Explosion-proof temperature switch (Model 4T*EA) is mounted on a wooden board during transportation. Please take off the wooden board and use these nuts and bolts for installation.
(4 sets of hexagon socket head cap bolt M10 x 40L, nuts, and spring washers)

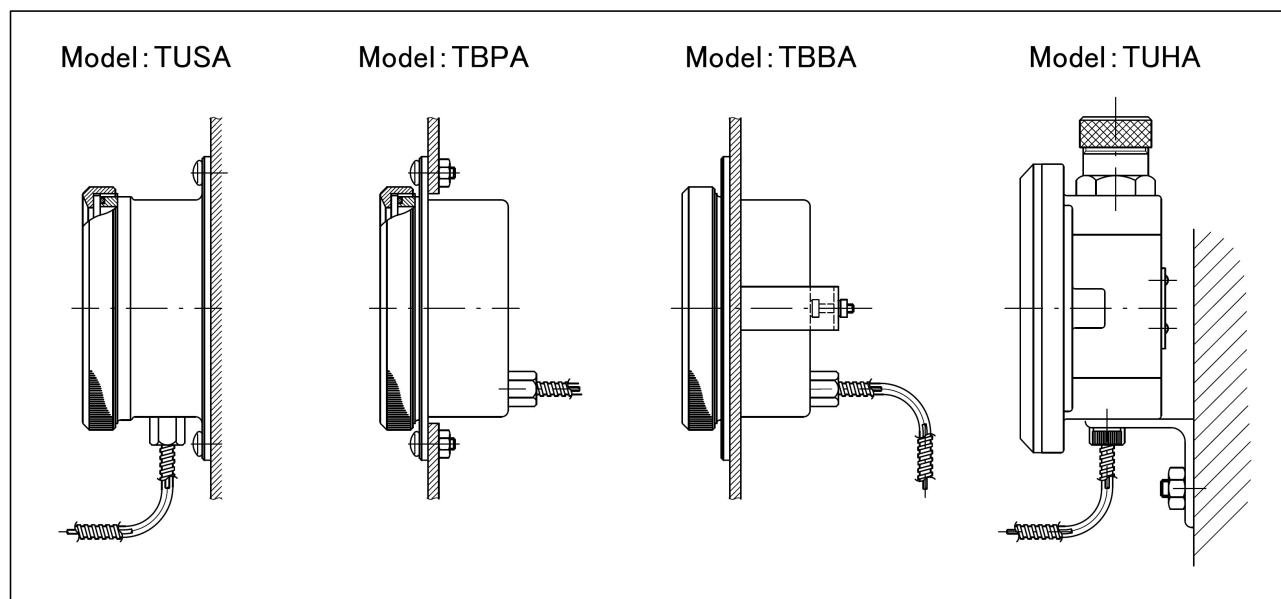

(2) Capillary

- Do not cut the capillary. It cannot be re-connected.
- Capillary is coiled in 150mm radius and shipped out from the factory. Be careful not to twist the capillary when un-coiling.
- During installation, be careful not to step on the capillary or damage it with any mounting equipment.
- If the capillary is too long, please wind up the un-used capillary in 100mm radius or larger and bind it near the indicator.
- Minimum bend radius of a capillary is 50R. Please do not bend the capillary smaller than this value. The capillary may break or get clogged up and lead to temperature indication error.
- Please make sure the capillary is protected from excessive heat such as sparks from welding. Capillary itself may break or the internal fluid may be affected and lead to malfunction.
- You may not get an accurate temperature reading when the capillary is locally heated or cooled if the temperature gauge is case compensation. Please change to a full compensation type, or remove the capillary away from the heating/cooling environment.

(3) Sensing-bulb

- There are 4 types of sensing-bulb.
 - Sliding union: Connection thread can slide and be fixed anywhere on the sensing-bulb.
 - Adjustable union: Connection thread can be adjusted approx. ± 5 mm on the sensing-bulb.
 - Fixed union: Connection thread is completely fixed in position and cannot be adjusted.
 - Plain bulb: Sensing-bulb without connection thread.

Note

- Sliding and adjustable union must be used with a thermowell.
- Sensing-bulb must fully be in contact with the measuring medium for accurate measurement.
- Please refer to the next page for detailed instructions on how to install the sensors.

Ⓐ Sliding and adjustable union

1. Loosen and remove the connection thread
2. Attach the connection thread to the thermowell or on other installation location.
3. Place the sensing-bulb into the connection thread.
4. Tighten the fixing screw at your desired measuring position until the sensing-bulb is completely fixed. In case of using a thermowell, insert the sensing-bulb all the way until it reaches the tip of the thermowell, and then tighten the fixing screw.

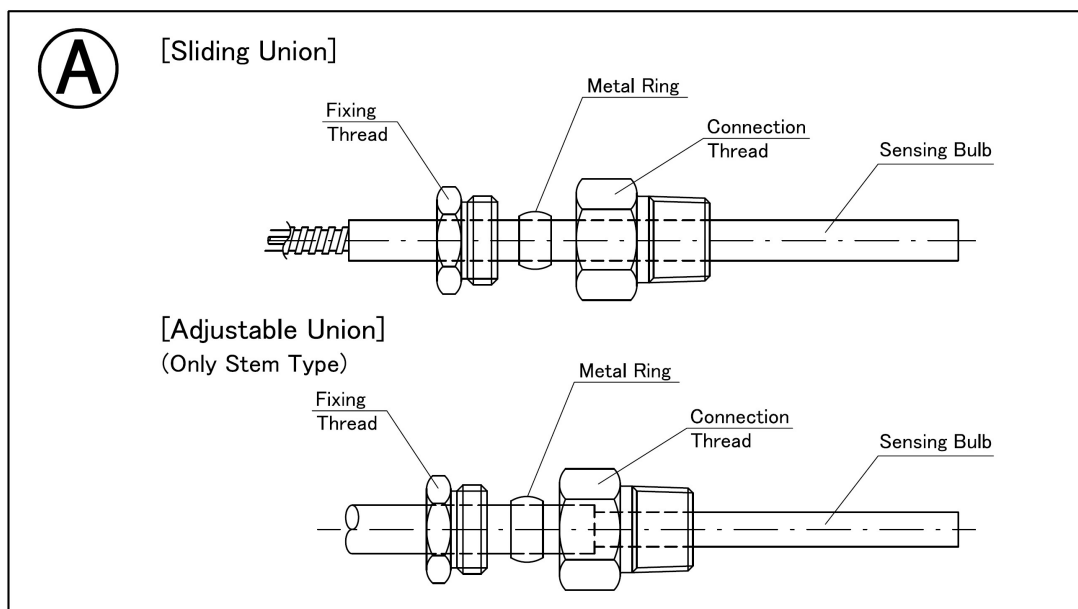

Ⓑ Fixed Union

1. Loosen and remove the connection thread
2. Attach the connection thread to the thermowell or on other installation location.
3. Place the sensing-bulb into the connection thread.
4. Tighten the fixing screw until the sensing-bulb is completely fixed.

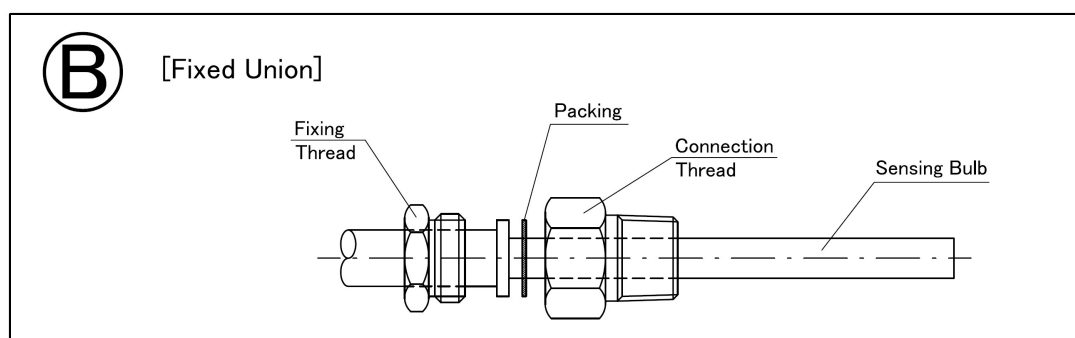

(4) Thermowell

We recommend the use of thermowell when:

- Measuring corrosive medium
- Pressure is applied to the sensing-bulb
- Measuring medium may eject when the sensing-bulb is taken off
- There is a flow of measuring medium (Please select drilled bar stock type)
- Sensing-bulb is sliding or adjustable union

6. Operation *Please go through the “Safety precautions” before you start the operation

(1) Product should be selected based on the following information.

- Operating temperature should be within 30~70% of the selected range.
- Set point of temperature switch should be within 20~80% of the selected range.
- Thermowell should be used for measuring corrosive medium.

Material selection will be under purchaser’s responsibility.

(2) Set point adjustment

- There are 2 types (Internal or external) of set point adjustment depending on the model.
- Be careful not to set the setting pointer above maximum range.

1) How to remove the cover of explosion-proof temperature switch

【Model: 3T*EA】

- Place a tool on the protruding part of the cover as per drawing below and turn counter-clockwise to remove the cover.

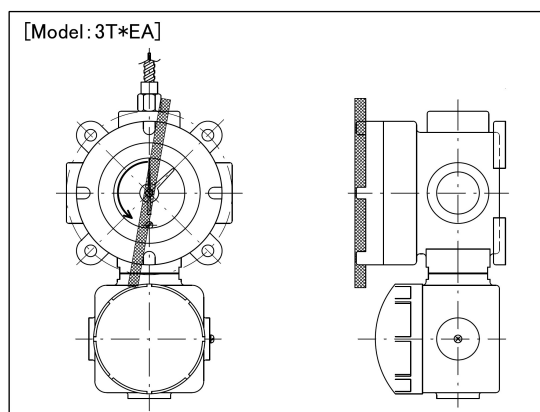

【Model: 4T*EA】

- Remove all 6 screws on the cover with a hex wrench. Tighten the lifting screw located at the top and bottom of the cover by turning them clockwise equally. The cover will rise and can be removed.
- The gap between the case and cover is designed precisely. The cover may get stuck and become un-removable if you disregard this procedure and forcibly try to remove the cover.

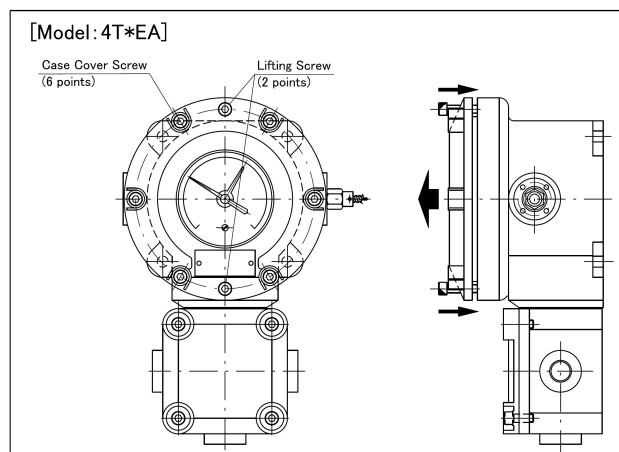

2) Internal adjustment procedure

1. Remove the cover and glass.
2. Use a flat-headed screwdriver and turn the setting screw to move the setting pointer to your desired temperature.
3. Place the glass and cover back on.

3) External adjustment procedure

1. Turn the external adjustment knob to move the setting pointer to your desired temperature.

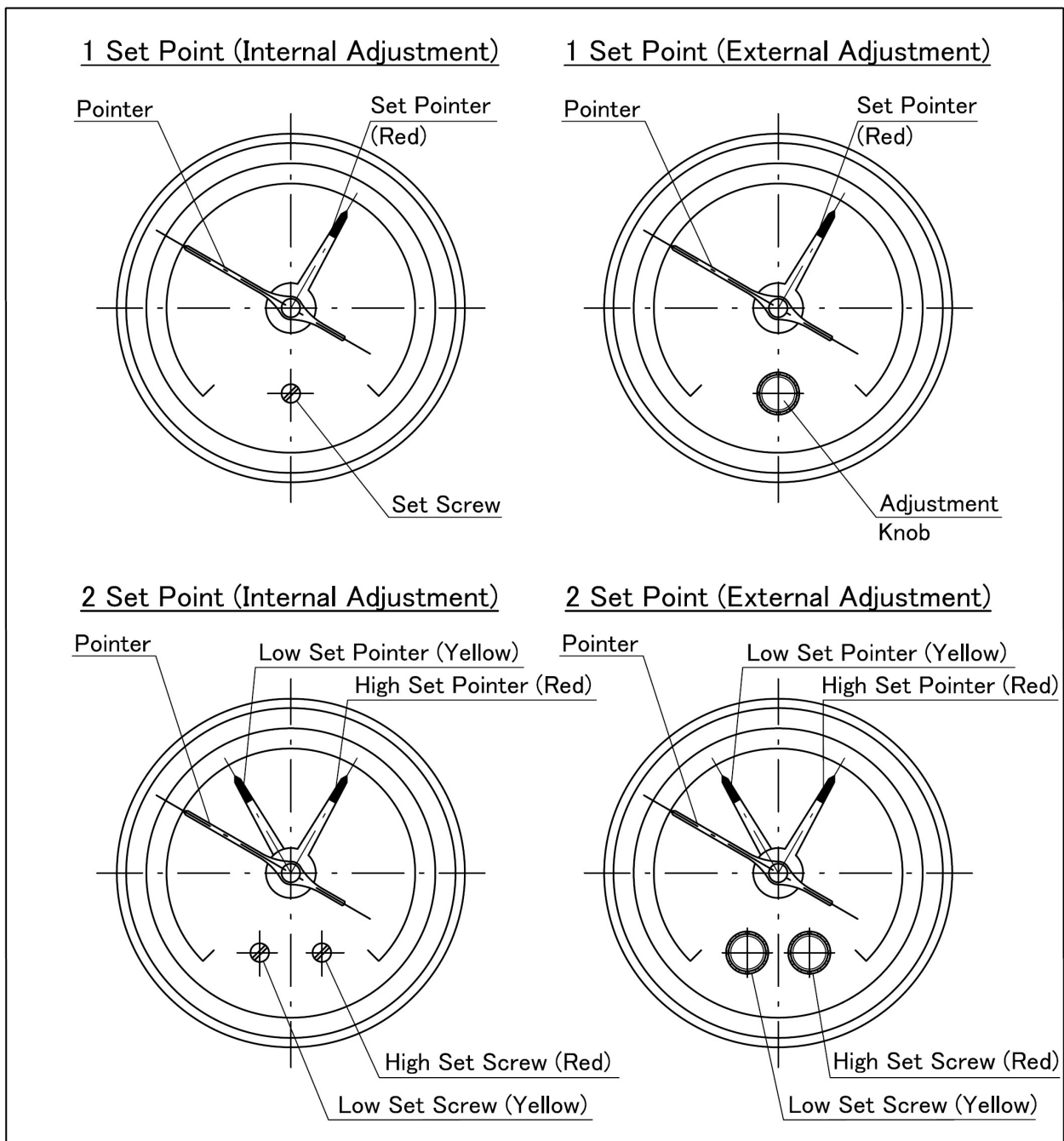

(3) Handling precautions

- Microswitch is not waterproof. Condensation measures must be taken to prevent insulation failure.
- Please check if the microswitch selected is suitable for the load in case of small current applications within DC5V1mA~DC30V26mA.
- Deadband cannot be adjusted.

(4) Set point operation

1) There are 3 terminals. C, NO, and NC. Operation (ON-OFF or OFF-ON) can be reversed by changing the wiring (e.g.: C-NO \Rightarrow C-NC). However, in case of 1 set point with 2 terminals and 2 set point with 4 terminals, operation cannot be adjusted at site.

2) Adjustment in case of set point shift

The set point is adjusted so that when the pointer overlaps on top of the setting pointer, the switch will operate and give out a signal. However, if in case you find a shift and the switch is not operating when the 2 pointers overlap, it can be re-adjusted by following the procedure below.

1. First check the data sheet and drawing, and scale plate to confirm the set point operation.
2. Turn off the power supply.
3. Connect the C with NC or NO using a tester.
4. Turn the setting screw slowly with a flat-head screw driver and find the point where the set point operates. Make sure the setting pointer does not exceed the maximum range.
5. After confirming the signal, move the setting pointer with your fingers underneath the pointer. (When doing this do not use the setting screw to move the setting pointer)
6. Turn the setting screw to move the setting pointer to your desired temperature, and then check to see if it operates normally at the set point. If minor adjustment is required, run through steps ④ ~ ⑥ again.

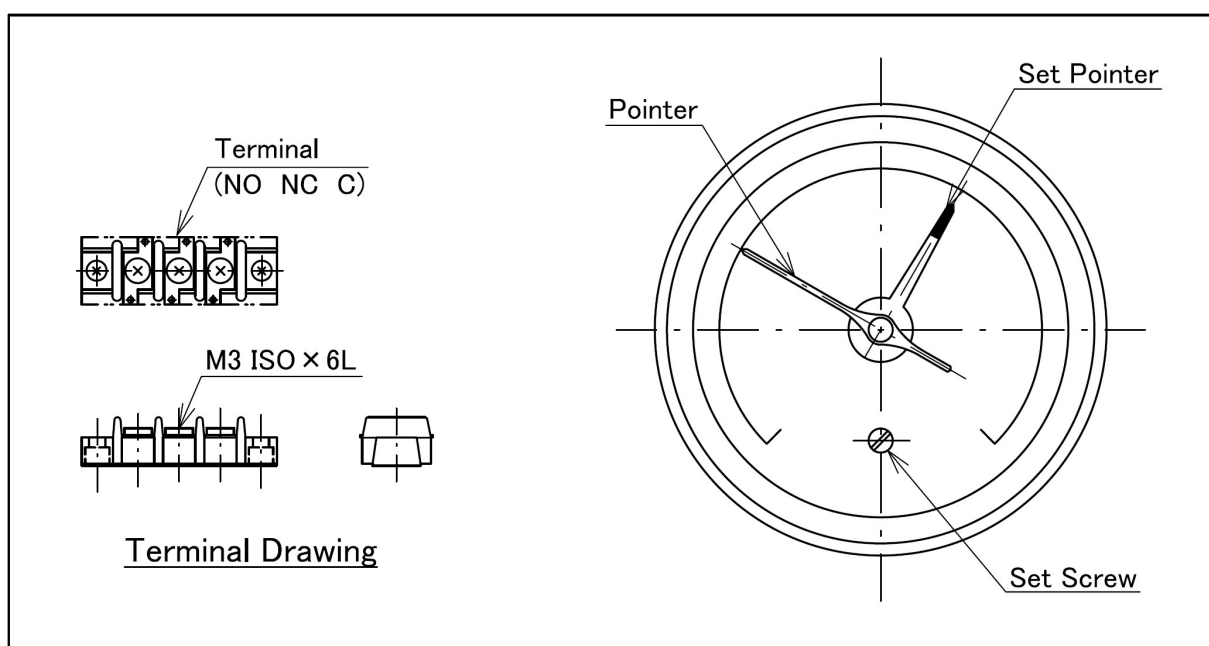

(5) DIN connector wiring (Model: DU/DR/DL)

1) Disassemble

1. Loosen the fixing screw. Pull and remove the cover from the connector.
2. Take off the fixing screw and gasket.
3. Remove the terminal block from the cover by inserting a small flat-head screw driver in the notch located at the base of the terminal block and prizing it up.
4. Remove the cable gland, washer, and rubber packing.

2) Wiring

1. Insert the cable gland, washer, and rubber packing on to the cable in this order and assemble it on to the cover (refer to the drawing below).
2. Peel off the cable sheath approx. 30mm and put on a crimped terminal.
3. Take off the captive screw from the terminal block (only need to loosen for Y-type terminal). Put on a crimped terminal and tighten the captive screw back on.

* tightening torque should be $0.5\text{N}\cdot\text{m}\pm 15\%$

* Bare wire can also be used. Loosen the captive screw and insert the wire, and tighten the screw back on.

* The maximum size of O and Y type crimped terminal will be $1.25\text{-}3.5\text{ mm}^2$.

* Cable O.D. can be within $\phi 6\sim 11$. However, for cable O.D. $\phi 9\sim 11$, please take off the inner part of the rubber packing before use.

3) Assembly

1. Put the cover back on the terminal block. (Press until it snaps back on).
2. Insert the rubber packing and washer into the cover in this order and tighten the cable gland.
3. Place the gasket in between the terminal block and the plug outlet of the temperature gauge, and tighten on the fixing screw. (tightening torque should be $0.5\text{N}\cdot\text{m}\pm 20\%$)

* Connector can be rotated 90 degrees in any direction by changing the way of assembly.

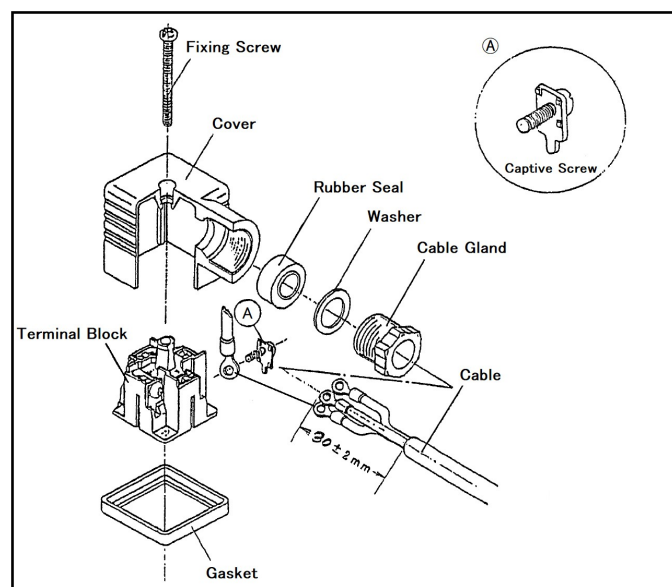

(6) Angle adjustment of aluminum case angle adjustable gauge (Model : SANA)

Angle adjustable gauge (aluminum case) can be adjusted as per below.

Ⓐ Can be adjusted forward and backward by 45 degrees at 3 points.

1. Loosen the fixing bolt
2. Take off the adjusting screw
3. Adjust the angle to your preferred position and place the adjusting screw back on.
4. Tighten the fixing bolt.

Ⓑ Can be adjusted left and right within 90 degrees

1. Loosen the fixing thread.
2. Adjust the angle left or right within 90 degrees to your preferred position.
3. Tighten the fixing thread.

Note: Please avoid changing the angle frequently. The product should be installed where there is less vibration and ambient temperature fluctuation. Please install the product in vertical position.

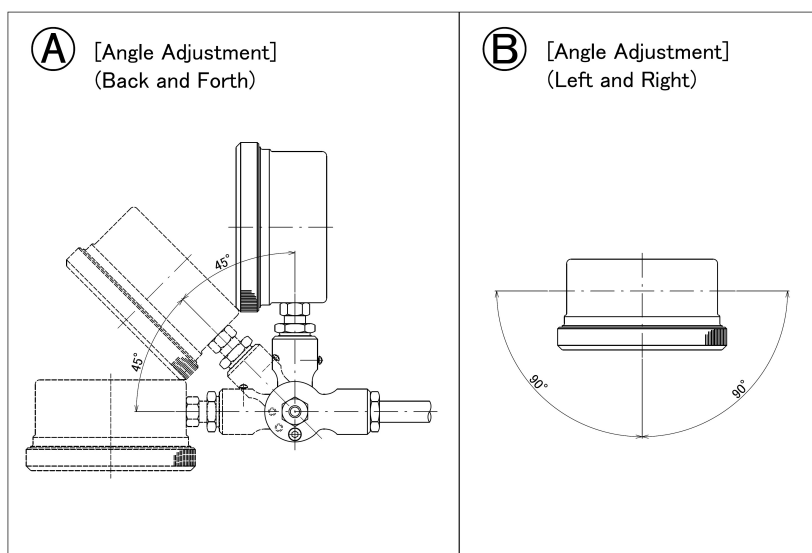
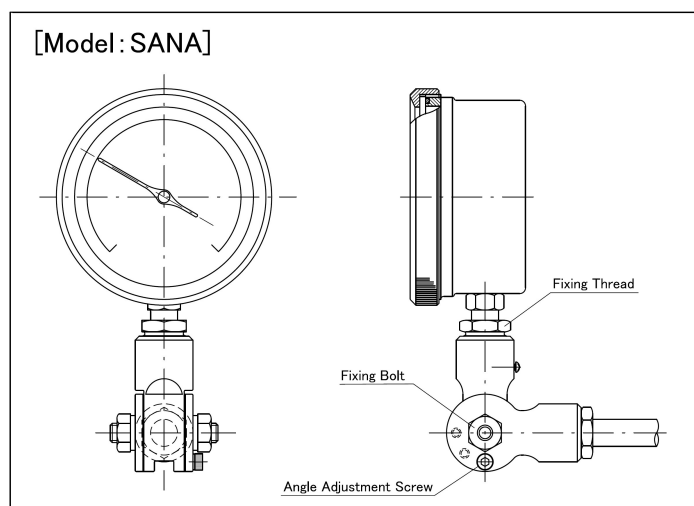

(7) Angle adjustment of SS case angle adjustable gauge (Model: 4SBA3S)

Angle adjustable gauge (SS case) can be adjusted as per below.

- Can be adjusted forward and backward by 45 degrees at 3 points.
 1. Take off the adjusting screw.
 2. Press the angle adjusting button.
 3. Adjust the angle to your preferred position and release the button.
 4. Tighten the adjusting screw.

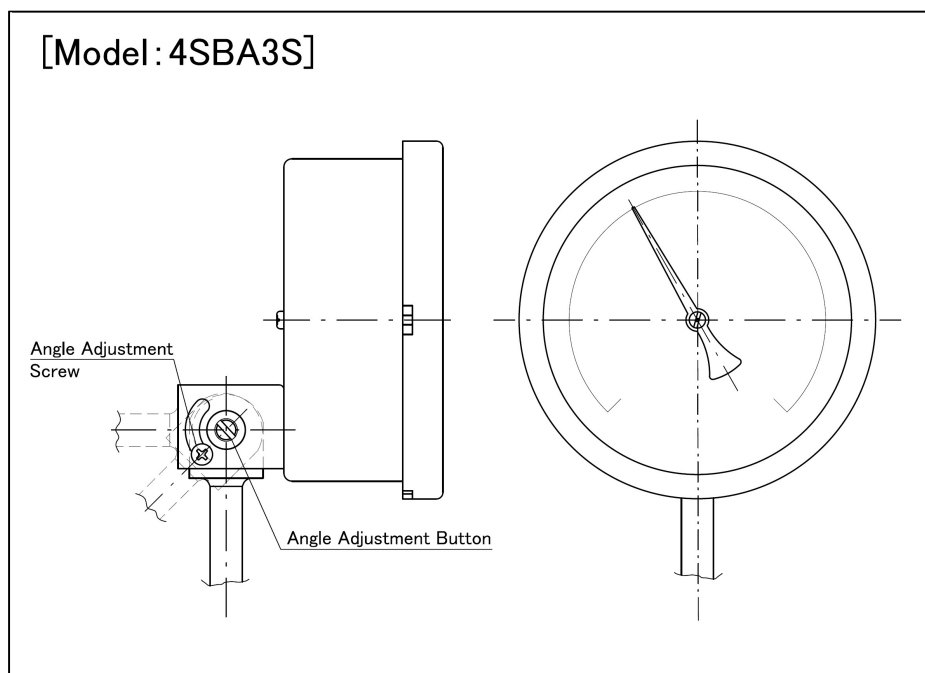

(8) Wiring of explosion-proof temperature switch (Model: T*EA)

1) Conduit pipe connection

- There is a conduit pipe connection port located at the bottom of the junction box.
- Please use a cable that has O.D. $\phi 14$ or smaller.

2) Flameproof cable gland

- There is a flameproof cable gland at the bottom of the junction box. Please use a cable that suits to the size of the cable gland.
- Loosen the gland nut and insert the cable into the cable gland. Tighten the gland nut and fix the cable.
- Tip of the cable gland is PF1/2(F). Once the cable gland installation is completed, proceed with wiring with conduit pipe.

7. Maintenance

- Maintenance checkup should be held at least once a year regardless of legal regulations.
- When cracks are found on the surface glass, please exchange to a new glass.
- Remove the product from the scene and carry out an accuracy check by using a traceable standard gauge. By taking record of the accuracy test constantly, you will be able to learn the characteristic of the product. If the characteristic changes and accuracy becomes out of tolerance, please contact Nesstech or the agent you purchased the product from to have the product repaired.

Warning

- Make sure the product is in proper condition with nothing unusual before maintenance work. In case there is anything unusual, do not take any further action as it may be very dangerous. Please find out the reason of product failure and confirm safety before continuing your work.

Caution

- Do not proceed any maintenance work with wet hands or tools.
- Open the case only when the weather is fine and dry with less humidity.
Avoid days after raining. Remaining moisture inside the case will lead to condensation.
- Please always wear your gloves when removing the glass to prevent from cutting your hands by the edge of the glass.
- The glass may be broken from the vibration and/or shock during transportation. Please be very careful when removing broken glasses.

(1) Maintenance work *Please go through the “Safety precautions” before any maintenance work

【Tools to be used】

- Flat-head screw driver
- Gloves
- Strap wrench (if necessary)

This temperature gauge has been tested at our factory against a standard gauge traceable to the national standard, and hence it is not advisable to do any adjustment at site.

However, if in case urgent adjustment needs to be made at site, please follow the procedure below.

*Zero adjustment by anyone other than Nesstech will void the warranty.

(2) Zero adjustment procedure

Temperature gauge and switch (External adjustment)

1. Please confirm the external zero adjusting screw located at the back of the case.
2. Turn the screw with a flat-head screw driver and adjust to your preferred temperature. Pointer can be moved ± 15 degree of angle from the initial position. Adjusting the pointer past ± 15 degree of angle will lead to product failure. Span cannot be adjusted at site.
3. Please check the accuracy after zero adjustment at mid-point of scale or at boiling point of water to ensure correct reading.

* If the accuracy cannot be adjusted within $\pm 2\%$ F.S., please return the product to our factory for further assistance.

Explosion proof temperature switch (Internal adjustment)

1. Remove the cover (refer to page 10 for detailed instruction)
2. Hold the pointer and the center adjustment knob as per the figure below and turn the adjustment knob slowly. Do not move the hand holding the pointer to avoid the pointer from bending or breaking.
3. Place the cover back on after zero adjustment is completed.

*It is difficult to open/close the cover at site. We highly recommend to send the unit back to our factory for zero adjustment.

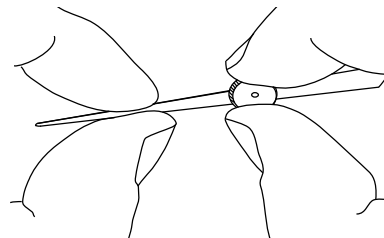

(3) Exchanging surface glass

Temperature gauge and switch

- ① Remove the cover by turning it counterclockwise. Hold the case firmly and loosen slowly so the surface glass does not fall off and break. Use a strap wrench if you cannot remove it by hand.
- ② Remove the Glass and gasket. Use gloves to prevent from cutting your hands by the edge of the glass. If the glass is stuck on to the case, do not force to remove by using screwdrivers or other tools. The glass or gasket could get damaged. It will come off gradually.
- ③ Exchange the surface glass, place the gasket and tighten the cover back on by turning it clockwise.

Explosion proof temperature switch

Surface glass of an explosion proof temperature switch cannot be exchanged at site.

Please contact your nearest sales agent or our factory for further assistance

(4) Handling precautions for oil filled temperature gauge (Model: **HA)

- Please refill the oil in case of oil shortage. Lack of proper amount of oil may cause corrosion of the Internal mechanism and degrade the anti-vibration performance.
- Please take extra care not to damage the surface glass. The oil will leak out if the surface glass is broken. Please apply proper protection if necessary.
- In case of oil shortage, please refill the gauge following the procedure below.
 1. Remove the oil cap and take out the seal cover.
 2. Use a dropper or pour it along a thin stick and gradually fill the oil.
 3. Oil should be filled all the way to the top of the glass disc.
 4. Place the seal cover and tighten the oil cap firmly with your hands.

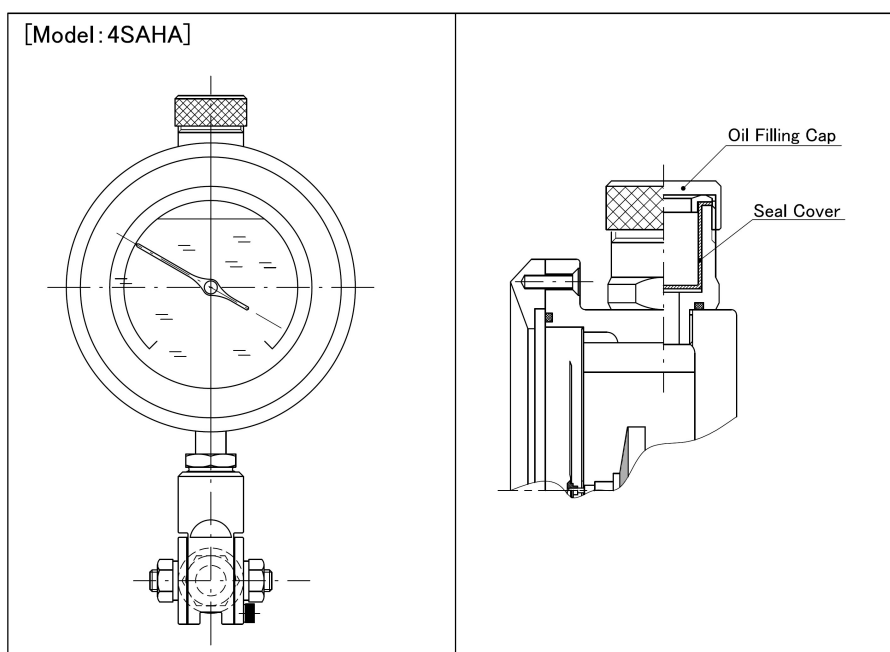

(5) When there is condensation

- Condensation may occur depending on the surrounding environment of the place of installation. In case of condensation, please refer to the exchanging surface glass procedure on page 17 to remove the surface glass, and wipe off the moisture. Before putting the glass back on, make sure the inside of the gauge is fully dried.
- Condensation is not a product failure, but if it occurs frequently, please contact your nearest sales agent or our factory for further assistance.

(6) Spare parts

- Only surface glass, gasket, and cover will be available as spare parts.
- We recommend to keep a complete set of gauge as spare parts.

8. Trouble-shooting

Problem observed	Possible reason	Solution
Gauge is indicating higher than the actual temperature	Somewhere along the capillary is heated The capillary for temperature compensation may be leaking	Remove the heat source or change to double capillary type Consult factory
The gauge is indicating lower than the actual temperature	Somewhere along the capillary is cooled Sensing-bulb is not fully in contact with the medium Initial symptoms of leakage	Remove the cooling source or change to double capillary type Install in a place where sensing-bulb is fully in contact with the medium Consult factory
The pointer will not move	Leakage or clog in the capillary	Consult factory
Discoloration of oil inside case (Only for oil filled gauges)	Effect of direct sun light, or deterioration over time	Consult factory
Switch will not operate when the temperature reaches the set point (Only for temperature switch)	Setting pointer has shifted Damaged microswitch due to overcurrent	Refer to set point adjustment on page 12. Consult factory if this will not solve the problem. Consult factory
Switch is chattering	Vibration at measuring point Microswitch failure	Install in a place where there is no vibration Consult factory

NESSTECH INC.

【 International Sales 】

1-12-1 Akanehama, Narashino-shi,

Chiba 275-0024, Japan

Phone: +81-47-453-6555

Fax: +81-47-453-1181

Email: global.sales@nesstech.co.jp

URL: <https://www.nesstech.co.jp>



Please contact Nesstech or the agent from where you purchased the product from for any questions, problems, or miss-indications within this manual.

We reserve the right to revise and amend the content of this manual without prior notice.